

V O L V O



Volvo Articulated Haulers 41 t 485 hp

A45G FS

Volvo Construction Equipment



Being the first. Keeping the lead.

Since introducing Gravel Charlie, the world's first series manufactured articulated hauler, Volvo has consistently led the way when it comes to pioneering technology which delivers unrivalled levels of sustainable productivity and performance.

Today we offer the most comprehensive range of articulated haulers in the industry, with common technology throughout, ensuring optimum results whatever size class you operate. Combined with a range of complementary services and solutions, you can count on Volvo Articulated Haulers to deliver the lowest possible cost per tonne.

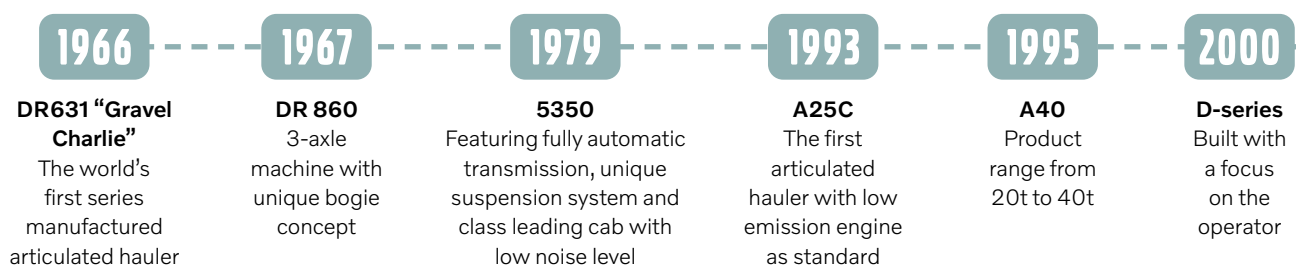



As part of our enduring focus on environmental care we are committed to Science Based Targets to achieve net-zero value chain emissions by 2040. From product planning through to end-of-life, our focus continues to be on minimizing our global footprint and driving transformation in our industry.



Follow our carbon reduction journey

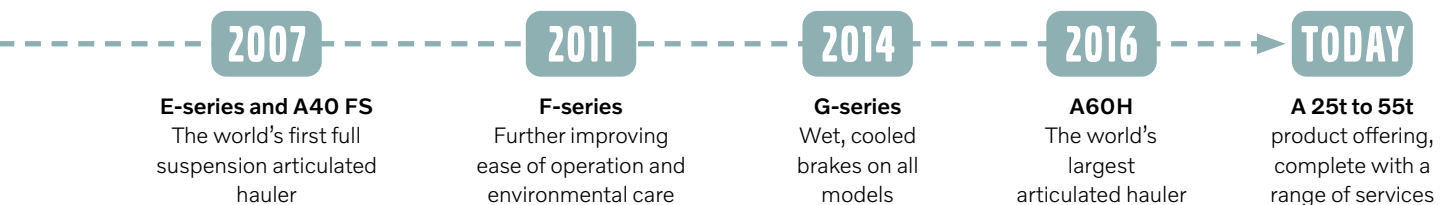

Keep on moving

Effective maintenance can have a big influence on your total cost of ownership. Volvo Articulated Haulers are designed to be easy to service, helping you to maximize your uptime and keep maintenance costs to a minimum.

Reduce oil volume by half

When measured over the lifetime of the machine, Volvo Articulated Haulers require less than half the fluid volume compared to competition, benefitting both the environment and your operating costs.



1,000hr engine service intervals

Volvo Engine Oil and High Performance Filters offer 1000 hour engine service intervals. The result is 50% less oil and filters – reducing maintenance requirements as well as your environmental impact.



Easy to service

Servicing your machine is quick and easy thanks to industry leading service access and essential maintenance points accessible from the ground. The front grill swings down, opening a service platform with anti-slip steps and the electric hood opens to 90 degrees, allowing full access to the engine compartment.



Service alerts

Fluid levels are constantly monitored with timely service alerts displayed on the dashboard, helping you stay on top of your maintenance requirements.





*Reduce your maintenance costs with Volvo
Articulated Haulers.*



NO DAILY OR WEEKLY GREASING

With Volvo Articulated Haulers greasing is only required every 250 hours – the best in the industry – delivering maximum uptime.

Haul Assist

Gain access to a set of tools designed to help you get the most out of your Volvo Articulated Hauler and boost your profitability.

Proactive tire management

Optimize tire life with the support of the Tire Pressure Monitoring System, which allows the operator to monitor tire pressure and temperature from the comfort of the cab.



A complete site overview

Monitor the whereabouts of all your machines, vehicles and visitors in real-time with Map, a connected tool which provides accurate positioning to help monitor on-site traffic and navigate the site more efficiently.



Go into detail

Reports can be generated automatically on a daily and weekly basis, or manually at any time, including the geo-tracking of moved material which is enabled by Map.



Support you can count on

As a fully integrated and factory-fitted Volvo system, all the components, hardware and software of Haul Assist are supported by your Volvo dealer to keep your operation running smoothly. What's more, you will benefit from over-the-air updates, easy upgrades and remote support.





The perfect Assist-ant to help get the most of your Volvo Articulated Haulers.



Watch our Haul Assist video ▶



TAKE CONTROL OF YOUR PRODUCTIVITY

On-Board Weighing provides real-time payload information which can help to eliminate carry-back and overloading; the result is peak productivity, reduced fuel consumption and less machine wear.

Move more for less

Boost your profits with Volvo Articulated Haulers, designed to deliver high productivity at the lowest cost per tonne.

Optimized payload

The machine is optimized for efficiency featuring high payload capabilities. Its smart design allows for more capacity while reducing fuel consumption so you can move more for less.



Volvo dynamic drive

Dynamic and predictive gear selection adapts to operating conditions, for improved comfort and fuel efficiency.



Simply the best

The machine delivers unbeatable off-road performance in its class with features including proven Volvo drivetrain, automatic drive combinations including 100% differential locks, all-terrain bogie and hydro-mechanical steering.



Smooth descent

Make your daily job easier with downhill speed control. The function automatically maintains a constant speed when operating on downward gradients and is the perfect alternative to the retarder pedal for a more efficient and comfortable shift.





*Volvo Articulated Haulers deliver
the highest profitability.*



INTELLIGENT EFFICIENCY

Experience superb fuel efficiency without compromising on power and performance thanks to the world-renowned Volvo drivetrain, including Terrain Memory. The intelligent function identifies and remembers slippery road segments to ensure optimized traction control – the result is excellent off-road mobility.

Comfort at speed

Rough roads? Just relax and step on the gas. The A45G FS features unique technology which delivers superior productivity, travel speed and cycle times when compared to other haulers.

Unique suspension

The unique front suspension is equipped with a set of accumulators and adapts to both payload and ground conditions, delivering unbeatable operator comfort. The rear suspension features two high pressure accumulators for loaded operations and two low pressure accumulators for unloaded operations. The cross flow between the hydraulic cylinders stabilizes both trailer and tractor, allowing for higher average speeds over poor ground structures.



Active leveling sensors

Six level sensors actively monitor the frame movement in relation to the axles and signal the hydraulic system to adjust the suspension, optimizing stability during travel.



Put to the test

This example shows how replacing conventional suspension haulers (A45G) with full suspension haulers (A45G FS) can have a large effect on your business. It's based on a fleet of 16 articulated haulers, with a total haul cycle of 3.1 kilometers.



Total fleet size -18%

By using Full Suspension haulers, you can reduce your fleet size to move the same amount of material.

Cost of ownership -13%

With fewer machines, delivering faster cycle times, the fleet total cost of ownership is reduced.

Average cycle time -20%

Due to the ability of the Full Suspension machine to drive faster over challenging terrain, cycle times are significantly reduced.

Cost per tonne -13%

A side-by-side study of an A45G compared to an A45G FS showed the A45G FS delivered a lower cost per tonne.

Productivity +25%

Faster cycle times result in an increase of hauler production per operating hour.



▲
**Watch The Race between
the full suspension and standard
suspension Volvo haulers**

Control in comfort

Featuring superior comfort, ease of operation and safety, the industry-leading cab appeals to operators and helps maintain productivity all day, every day.

Total control

Volvo Articulated Haulers are packed with features to help operators get the most from the machine. Intelligent functions such as cruise control, downhill speed control and hill assist help control the hauler with ease and efficiency, for enhanced safety and productivity in all conditions.



Ease of operation

The ergonomic, comfortable and easy-to-understand controls are designed to suit all operators. Additional automatic functions such as OptiShift – which enables fast and smooth directional changes – further enhance ease of operation.



Operator comfort

Feel comfortable and spend more time in the Volvo Articulated Haulers. The centrally positioned operator, superior steering, excellent suspension, low noise levels, climate control, space and visibility reduce operator fatigue for more effective operations.



Safety first

Whether its operators, trainers, technicians or site workers – safety on site is of fundamental importance. In the Volvo Articulated Haulers superior visibility and efficient lighting combine with features such as the brake test and dump support, helping to keep everyone working around the machine safe.





Volvo Articulated Haulers are the operator's number one choice.



OPERATOR'S CHOICE

A happy operator is a more productive operator and when many other machines are onsite, most operators prefer the Volvo. Even in the most adverse conditions, its comfortable cab and ease of operation keep operators alert and performing their best.

The ultimate Hauler

Only from Volvo

- Industry-leading Volvo engine and driveline: high performance, high fuel efficiency
- Terrain Memory function: optimized engagement of the traction control for excellent off-road mobility
- Volvo dynamic drive
- Automatic drive combinations including 100% differential locks, all-terrain bogie and hydromechanical steering
- OptiShift: fast and smooth directional changes

The operator's choice

- Ease of operation: ergonomic and easy-to-understand controls
- Centrally positioned operator for best-in-class visibility
- Cruise control, hill assist, dump support system, load and dump brake
- The downhill speed control function automatically maintains a constant speed when operating on downward gradients
- Built-in brake test: schedule and perform a stationary brake test, guided by the machine display

Solutions for you

- Easy machine monitoring: CareTrack, ActiveCare
- Genuine Volvo Parts
- Volvo Site Simulation: get recommendations on the best fleet configuration and site set-up
- Operator Training Program: unlock the full potential of your machine
- Uptime Services: control your maintenance costs

Proven full suspension concept

- Reduce total fleet size by 18%
- Reduce average cycle time by 20%
- Increase productivity by 25%
- Reduce cost per tonne and cost of ownership by 13%
- Unique suspension contributing to a smooth and productive ride
- Active leveling sensors deliver optimized stability



Haul Assist

- On-Board Weighing: real-time payload monitoring
- Tire Pressure Monitoring System
- Map: real-time positioning of on-site traffic
- Productivity Reports, including the geo-tracking of moved material
- Over-the-air updates, easy upgrades, remote support

Service and maintenance

- 250-hour greasing interval
- Half the fluid volume compared to the competition
- 1,000hr engine service intervals
- Service reminders and fluid level monitoring
- Industry-leading service access and ground-accessible service points



Configured for success

Ensuring your fleet is configured in the correct way can yield huge benefits to your operation including more productivity, enhanced performance and less costs.

Here are some tips to help tailor your new Volvo Articulated Hauler according to the application, site conditions and type of transported material, as well as matching to the appropriate loading unit. For more detailed information, talk to your Volvo dealer!

Body options

Question	Answer	Solution
Dealing with height restrictions? Operating in restricted height conditions e.g. silos or underground	No	Select standard body
	Yes	Select low profile body
Hauling abrasive material? Granite, silicate etc	No	<i>Go to next question</i>
	Yes	Select wear plates / rock liners for extended service life
What material density? Gravel is ~1.65 ton/m ³	> 1.5 ton/m ³ (gravel, blasted rock)	<i>Go to next question</i>
	1.1 - 1.5 ton/m ³ (dry earth, shale)	Select side extensions to increase body volume
	< 1.0 ton/m ³ (coal, fly ash etc)	Select light material kit to increase body volume
Front spill protection needed? Getting loaded by large excavator	No	<i>Go to next question</i>
	Yes	Select front spillguard
Extra load retention needed? Risk of dropping material e.g. when climbing steep inclines	No	<i>Go to next question</i>
	Yes, but not hauling boulders	Select tailgate – overhung type – to reduce spillage
	Yes, hauling boulders	Select tailgate – underhung type – to reduce spillage
Hauling sticky material? Risk of carry-back	No	<i>Go to next question</i>
	Yes	Select body exhaust heating

Exceeding gross machine weight is not permitted.
Payload should be reduced by the weight of the optional equipment.

Tires

Question	Answer	Solution
Operating on abrasive haulroad? Risk of tire cuts or extensive wear	No	E3 tires are optimized for soft ground, offering the best traction and high average speed
	Yes	Select E4 tires for the best cut resistance, comfort and tread life
Extra flotation needed? Risk of sinkage in soft ground	No	Select standard profile tires
	Yes	Select low profile tires, featuring lower ground pressure for improved flotation, stability and comfort



Optimal pass-matching

Volvo Excavator	EC380	EC480	EC530	EC550	EC750	EC950
	Number of passes					
A45G FS	11	8	7	6	5	4

- Excavator overcapacity, 3 buckets or below
- Well matched, 4-6 buckets (≈ 90 seconds loading time)
- Excavator undercapacity, 7 buckets or more
- Excavator undersized for optimum match

Volvo Wheel Loader	L150	L180	L220	L260	L350
	Number of passes				
A45G FS	6	5	5	4	3

- Loader overcapacity, 2 buckets or below
- Well matched, 2-3 buckets (≈ 90 seconds loading time)
- Loader undercapacity, 4 buckets or more
- Loader undersized for optimum match. Reach might also be an issue



Hauler chassis solutions

With Special Application Solutions and different chassis options you can tailor Volvo Articulated Haulers to your specific needs.



Volvo A45G FS in detail

Engine

V-ACT, 16 liter, 6-cylinder straight VGT (Variable Geometry Turbocharged) diesel engine with 4 valves per cylinder, overhead camshaft and electronically controlled unit injectors. It has wet replaceable cylinder liners and replaceable valve guides and valve seats.
The engine has cooled EGR (Exhaust Gas Recirculation) and exhaust after treatment with EAT-Muffler (Exhaust After treatment) including DOC (Diesel Oxidation Catalyst), DPF (Diesel Particulate Filter) and SCR (Selective Catalytic Reduction) with an electronically controlled UDS (Urea Dosing System).
After treatment system features passive DPF regeneration with an AHl (After treatment Hydro carbon Injection) device as back up.

Engine model	Volvo D16J (Stage V)	
Max power - SAE J1995 Gross	kW	357
	hp	485
at engine speed	r/min	1800
Flywheel power - ISO 9249, SAE J1349 Net	kW	354
	hp	481
at engine speed	r/min	1800
Max torque - SAE J1995 Gross	Nm	2 576
	Nm	2 551
Max torque - ISO 9249, SAE J1349 Net	Nm	2 551
	Nm	2 551
at engine speed	r/min	1 050
Displacement	l	16.1

Electrical System

All cables, sockets and pins are identified. Cables are enclosed in plastic conduits and secured to main frame. Halogen lights. Prewired for options. Connectors meet IP67 standard for water-proofing as necessary.

Voltage	V	24
Battery	V	2x12
Battery capacity	Ah	2x225
Alternator	kW/A	3.396/120
Starter motor	kW	9

Drivetrain

Torque converter with built-in lock-up function.

Transmission: Fully automatic Volvo PowerTronic planetary transmission with nine forward gears and three reverse gears. The transmission has the ability to skip gears for fast and accurate gear selection.

Dropbox: Volvo-developed, in-line design with high ground clearance and 100% longitudinal "dog clutch" type differential lock.

Axles: Heavy duty, purpose built Volvo design with fully floating axle shafts, planetary type hub reductions and 100% dog clutch type diff-lock. Automatic traction control system (ATC).

Torque converter	2.1:1	
Transmission	Volvo	PT 2529
Dropbox	Volvo	IL2 ATC
Axles	Volvo	ARB H40

Brake system

Fully hydraulic, wet multiple disc brakes with enclosed, forced oil-cooled multiple discs on all wheels. Two circuit brake system. Complies with ISO 3450 at total machine weight.

Circuit division: One circuit for front axle and one for bogie axles.

Parking brake: Spring-applied disc brake acting on the trailer unit propeller shaft. When the parking brake is applied, the longitudinal differential locked.

Retarder: Service brake retarder function and Volvo Engine Brake (VEB).

Steering System

Hydro-mechanical articulated steering, self compensating design. Two double-acting steering cylinders.

Steering angle: 3,4 steering wheel turns lock-to-lock, $\pm 45^\circ$.

Steering system, including secondary steering fulfills ISO 5010.

Chassis

Frames: box type, heavy duty. High strength steel, robot welded.

Rotating hitch: 100% maintenance free, fully sealed, with permanently greased tapered roller bearings.

Cab

Mounted on rubber pads. Ergonomically designed. Easy entry and exit. Wide angle forward view.

Operator centrally positioned above the front axle. Adjustable operators seat with retractable seat belt.

Tilt/telescopic steering wheel. Ergonomically positioned controls. Filtered air. Climate control system.

Operator communication system: Contronics.

Large color display, user-friendly and easy-to-understand information, all vital machine functions are constantly monitored.

Instructor seat with seat belt.

Safety: ROPS/FOPS standards approved according to ISO3471, SAE J1040 / ISO3449, SAE J231.

Sound level in cab (ISO 6396) - L _{PA}	dB	72
External sound level (ISO 6395) - L _{WA}	dB	112
Internal sound level with sound kit: 70 dB(A)		
External sound level with sound kit: 110 dB(A)		

Hydraulic system

Pumps: Four variable displacement piston pumps driven by the flywheel PTO.

Two load-sensing used for steering and tipping and two electrical controlled used for fan, brake cooling and brake power supply.

One ground-dependent piston pump for secondary steering mounted on the dropbox.

Two return oil filters with magnetic cores provide effective oil filtration.

System max working pressure	MPa	26
-----------------------------	-----	----

Dumping System

Patented Load and Dump Brake.

Dumping Cylinders: two single stage double acting cylinders.

Tipping angle	°	70
Tipping time with load	s	12
Lowering time	s	10

Body

Plate thickness

Front	mm	8
Sides	mm	11
Bottom	mm	14
Chute	mm	16

Material

HB450 steel

Yield strength	N/mm ²	1 150
Tensile strength	N/mm ²	1 350

Load Capacity

Standard Body

Load capacity	kg	41 000
Body, struck	m ³	19.7
Body, heaped 2:1	m ³	25.1

With overhung tailgate

Body, struck	m ³	20.2
Body, heaped 2:1	m ³	26.2

Suspension

Unique, full hydraulic, on all wheels with automatic leveling and stabilizer. Part of the machine's hydraulic system, uses the same hydraulic oil.

Hydraulic cylinders (struts), front/rear	2/4	
Accumulators, oil-nitrogen, high pressure, front	2	
Accumulators, oil-nitrogen, high/low pressure, rear	2/2	
Levelling sensors	2+2+2	

Specifications

REFILL CAPACITIES

Crankcase	l	55
Fuel tank	l	480
Cooling system	l	49
Brake cooling system	l	188
Transmission	l	43
Dropbox	l	9
Axles, front/bogie	l	26/52
Hydraulic tank	l	210
AdBlue®	l	39

®registered trademark of the Verband der Automobilindustrie e.V. (VDA)

OPERATING WEIGHT UNLOADED

Tires		29.5R25*
Front	kg	17 000
Rear	kg	14 900
Total	kg	31 900
Payload	kg	41 000

Operating weight includes all fluids and operator

*) A45G FS with tires 875/65R25, add 300 kg/axle

TOTAL WEIGHT

Tires		29.5R25*
Front	kg	21 150
Rear	kg	51 750
Total	kg	72 900

*) A45G FS with tires 875/65R25, add 300 kg/axle

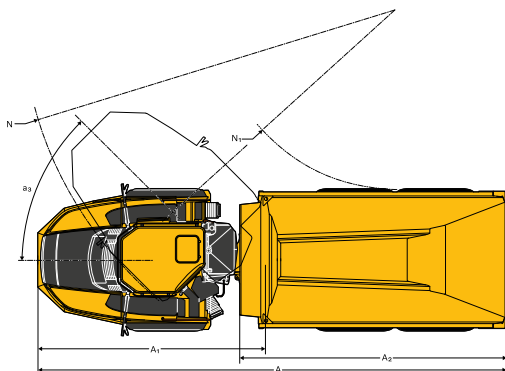

DIMENSIONS

Pos	Unit	A45G FS
A	mm	11 263
A ₁	mm	5 476
A ₂	mm	6 404
B	mm	5 844
C	mm	3 599
C ₁	mm	1 772
D	mm	3 100
D ₁	mm	2 942
E	mm	1 277
F	mm	4 518
G	mm	1 940
H	mm	1 706
I	mm	495
J	mm	3 200
K	mm	2 435
L	mm	822
M	mm	7 265
N	mm	8 957
N ₁	mm	4 327
O	mm	3 430

SPEED

Forward		
1	km/h	5.8
2	km/h	8.5
3	km/h	10.4
4	km/h	15
5	km/h	21.6
6	km/h	27.3
7	km/h	36.1
8	km/h	47.8
9	km/h	57
Reverse		
1	km/h	6.5
2	km/h	9.4
3	km/h	18

GROUND PRESSURE

Tires		29.5R25	875/65R25
Unloaded			
Front	kPa	114	100
Rear	kPa	48	43
Loaded			
Front	kPa	143	125
Rear	kPa	174	152

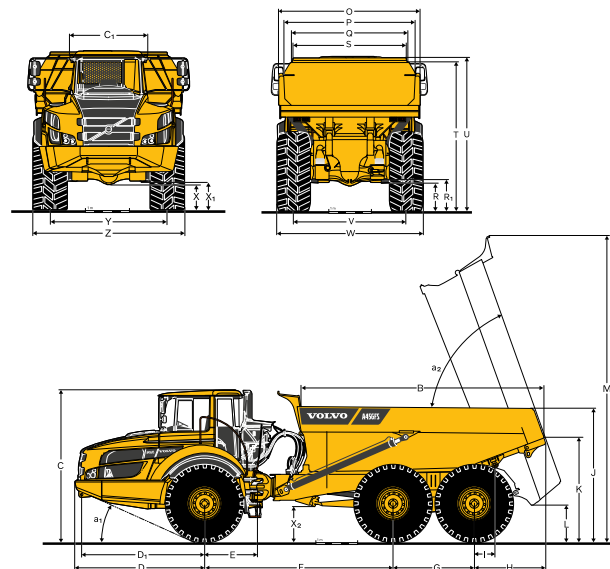

DIMENSIONS

Pos	Unit	A45G FS
P	mm	3 118
Q	mm	2 820
R	mm	613
R ₁	mm	640
S	mm	2 651
T	mm	3 427
U	mm	3 546
V	mm	2 636
W	mm	3 403
X	mm	553
X ₁	mm	640
X ₂	mm	788
Y	mm	2 636
Z	mm	3 403
a ₁	°	25
a ₂	°	70
a ₃	°	45

A45G FS: Unloaded machine with 29.5R25 tires.

Equipment

STANDARD EQUIPMENT

Engine

Direct injected, electronically controlled, turbocharged, intercooled
 Grouped oil filters
 Preheater for easier cold starts
 VEB (exhaust retarder EPG + compression brake)

Tires

29.5R25

Drivetrain

6x4 and 6x6 automatically engaged drive modes
 Dog clutch type 100% diff-locks in all axles
 Full automatic transmission
 Dropbox with longitudinal diff-lock
 Torque converter with automatic lock-up

Electrical System

120 A alternator
 Battery disconnect switch
 Extra 24 V socket for lunch cooler

Lights:

Back-up light
 Brake lights
 Cab lighting
 Direction indicators
 Headlights
 Instrument lighting
 Parking lights
 Rear lights

Brake system

Hill assist
 Load & Dump Brake
 Retarder pedal
 Parking brake on propeller shaft
 Two circuit, fully hydraulic, wet discs on all axles

Body

Body prepared for exhaust heating and optional equipment

Safety

Anti-slip steps and platforms
 Dump body lock
 Handrails on steps and platforms
 Hazard lights
 Horn
 Protective grill for cab rear window
 Rear-view mirrors
 Retractable 3-inch safety belt
 ROPS/ FOPS - certified cab
 Secondary steering
 Steering joint lock
 Windshield washers
 Windshield wipers with interval function
 Dump support system

STANDARD EQUIPMENT

Comfort

ACC control panel
 Ashtray
 Cab heater with filtered fresh air and defroster
 Can holder /storage tray
 Cigarette lighter
 Instructor seat with seat belt
 Overhead console for radio
 Sliding window
 Space for lunch cooler
 Storage box
 Sun visor
 Tilt/telescopic steering wheel
 Tinted glass

Operator information interface

Gauges:
 Brake pressure
 Fuel
 Speedometer
 Tachometer
 Wet disc brakes cooling oil temperature

Warning lights grouped and easy to read

Central warning (3 levels) for all vital functions

Central positioned information display

Automatic pre-start checks
 Clock
 Hour meter
 Operational information, easy-to-navigate menu
 Troubleshooting diagnostics

Exterior

Front mudguard wideners and rear mudflaps

Service and maintenance

Electrical engine hood
 Drainage hose
 Machine Tracking Information System MATRIS
 Service platform integrated in the front grill
 Tool box

OPTIONAL EQUIPMENT

Engine

Air filter, heavy duty, EON
 Engine heater, 240 V
 Engine heater, diesel (Eberspächer)
 Engine auto shutdown
 Engine shutdown timer
 External emergency engine stop
 Fuel filter, extra
 High engine idle speed

Tires

875/65R25

OPTIONAL EQUIPMENT

Electrical System

- Headlights, LED
- Warning beacon, LED
- Working lights, halogen
- Working lights, LED
- Entrance light
- Anti-theft system (pin code)
- Rear view camera
- Reverse alarm
- CAN-BUS interface, extra

Cab

- Noise reduction kit (fulfils 2000/14/EC)
- Anchorage, operator's manual
- Cab heating/ventilation timer
- Cable kit, for cab heater 240 V
- HEPA cab air filter
- Bluetooth radio kit
- Rear view mirrors, adjustable, el.heated
- Seat belt XXL, non-retractable
- Sun blinds, side windows
- Universal key
- Air suspended, heated, fully adjustable seat
- Armrest for operator seat
- Headrest for operator seat
- Low profile cab

OPTIONAL EQUIPMENT

Body

- Body exhaust heating
- Front spillguard, extra
- Side extension, 200 mm
- Side extension, light material
- Tailgate, overhung, linkage-operated
- Tailgate, overhung, wire-operated
- Tailgate, underhung
- Wear plates, 450 HB
- Underground body

Safety

- Fire suppression system
- Warning triangle
- First aid kit and fire extinguisher
- Fire extinguisher
- Wheel chocks

Service and maintenance

- Lube system, standard machine
- Lube system, tailgate
- Lubrication hose, ground level greasing
- Tool kit

Other

- Siberian kit -40°C
- Arctic oil kit
- CareTrack
- Fast fuelling system
- Jump start connector, NATO -type
- Frame extension
- Haul Assist - On-Board Weighing
- Haul Assist - Tire Pressure Monitoring System

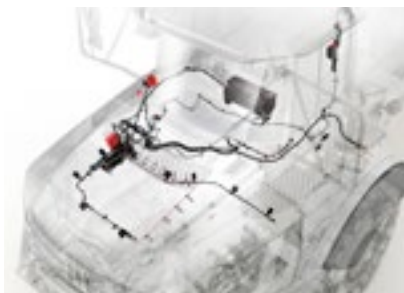
SELECTION OF VOLVO OPTIONAL EQUIPMENT**Fire suppression system****Fast fuelling****Heavy duty air filter****LED lighting****Entrance light****Wear plates**

Not all products are available in all markets. Under our policy of continuous improvement, we reserve the right to change specifications and design without prior notice. The illustrations do not necessarily show the standard version of the machine.

Solutions for you

Our industry leading machines are just the start of your relationship with Volvo. As your partner, we have developed an extensive range of additional solutions to help you improve uptime, boost productivity and reduce costs.

Our portfolio of products and services is designed to complement your machine's performance and boost your profitability. Simply put, we offer some of the best guarantees, warranties and technological solutions in the industry today. Below are just some examples. Talk to your dealer to find out and discuss the right fit for you!



Get the most from your machine

While reliable and efficient machines of course play a vital role in reducing costs, enhancing safety and maximizing productivity, it is ultimately the performance of the operator that really makes the difference. We offer a range of training initiatives to help operators unlock the full capability of their Volvo Articulated Hauler.

Connected to Uptime

Maximize machine uptime and reduce repair costs with the CareTrack telematic system. Choose to keep track of your machine yourself or let us take care of it with ActiveCare. Our Volvo Uptime Center will provide 24/7 machine monitoring, supplying weekly reports and notifying you should preventive maintenance action be required.

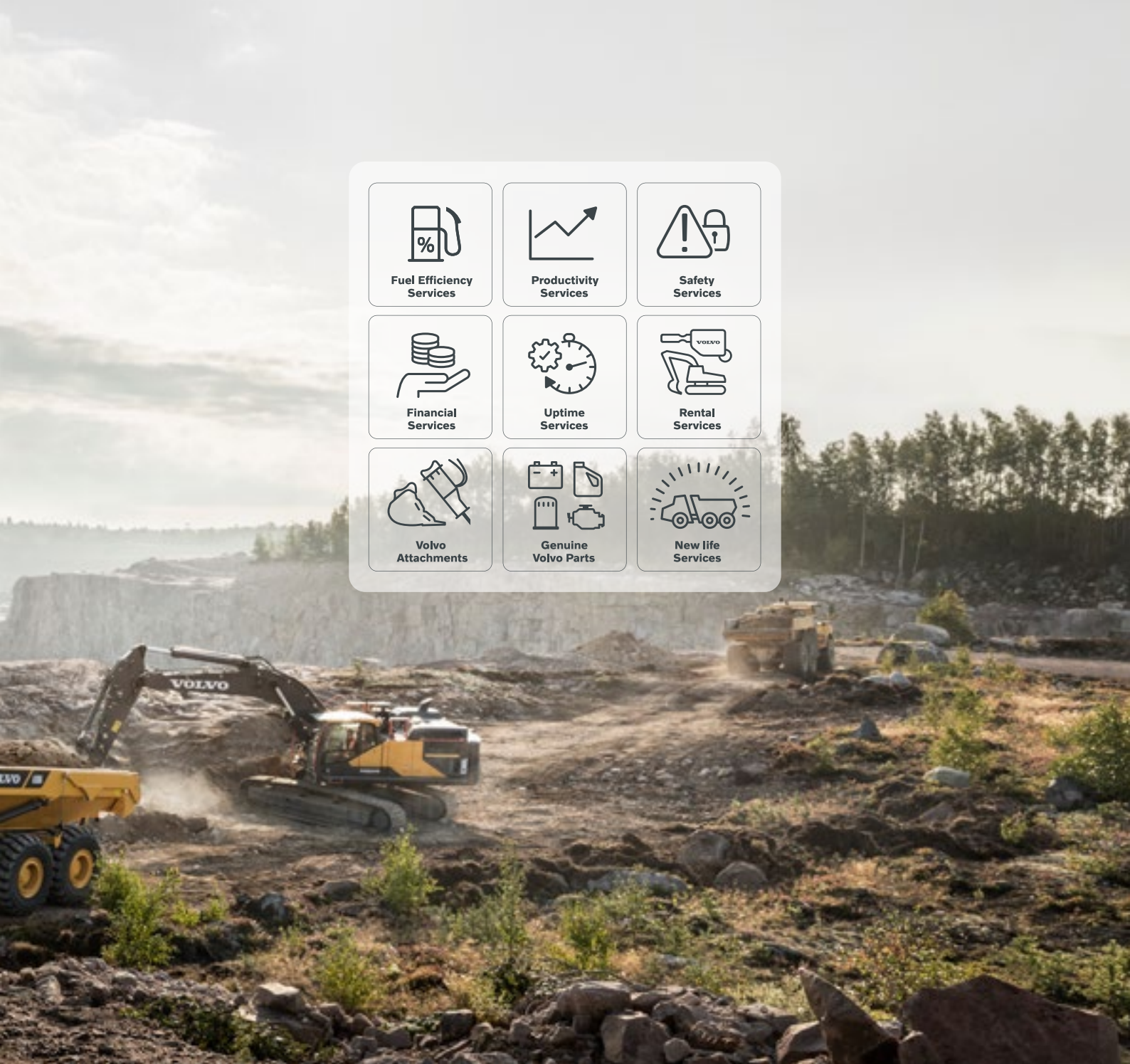

Fuel Efficiency Services



Productivity Services



Safety Services



Financial Services



Uptime Services



Rental Services



Volvo Attachments



Genuine Volvo Parts



New life Services

Control your maintenance costs

Stay on track with planned servicing and keep your asset covered with our range of flexible maintenance and repair agreements.

Optimize site efficiency

Using Volvo Site Simulation, we can help you make on-site logistics more efficient and lower your cost per tonne. Get recommendations on the best fleet configuration and site set-up to maximize profitability.

Genuine Volvo Parts

Maintain productivity and machine uptime with our range of readily available, tested and approved parts – all backed by Volvo warranty. Only by using Genuine Volvo Parts, can you protect your investment, extend machine life and guarantee long-lasting performance.

V O L V O